

MICROLIT KENO PRO |

Multi-Purpose Vacuum Aspirator
for Laboratory Waste Handling



OPERATION MANUAL

EXPERIENCE PRECISION

General Safety Instructions	1
Operating Limitations & Restrictions	1
Environmental & Installation Limits	1
Electrical Limits	2
Operational Restrictions	2
Material Compatibility	2
Storage Conditions	2
Intended Purpose	2
Intended Users	2
Intended Environment	3
Uses Not Intended	3
Overview	3
Installation Requirements	5
Installation & Setup	5
Cleaning, Disinfection and Sterilization	8
Maintenance & Service	9
Service & Repairs	10
Technical Specification	10
Troubleshooting	11
Warranty	13
Guidelines for Return	13
Disposal	13

General Safety Instructions

Read this manual carefully before operating the instrument and comply with all safety instructions provided herein.

- Only trained and authorized personnel are permitted to operate the instrument.
- Ensure that the power outlet is properly grounded before switching on the instrument.
- Always wear appropriate personal protective equipment (PPE) while operating the instrument.
- Place the instrument on a stable, clean, dry, non-slip and fire-resistant surface in a well-ventilated indoor area.
- Do not operate the instrument outdoors, near water or in proximity to hazardous or explosive substances.
- Use only safe, suitable, and compatible containers for liquid aspiration.
- Ensure that the supply voltage matches the rating specified on the product label before connecting the instrument to the power supply.
- Inspect the instrument, power adapter, tubing, and accessories for visible damage before each use. Do not operate the instrument if any damage is detected.
- Use only the original KENO PRO Vacuum Aspirator mains adapter supplied or approved by the manufacturer.
- Check that all accessories are correctly installed and securely connected before operation.
- Do not touch valves, pumps, tubing or internal components during operation.
- Do not move or relocate the instrument while it is operating.
- In the event of liquid spillage, immediately switch off the instrument, disconnect it from the power supply, clean the spill thoroughly and remove any organic solvents before resuming operation.
- Unplug the instrument only after it has completely powered down.
- Only qualified service personnel authorized by the manufacturer may open the instrument housing.
- Do not place heavy objects on the instrument.

Operating Limitations & Restrictions

The KENO PRO Vacuum Aspirator shall be operated only within the limits specified in this section. These limitations define the permissible environmental, installation, electrical, and operational conditions necessary to ensure reliable performance and prevent equipment damage.

Environmental & Installation Limits

Maximum operating altitude: 2000 m above sea level

Operating temperature: 0°C to 40°C

Storage temperature: 5°C to 40°C

Maximum relative humidity: 80% (non-condensing)

Installation category: Indoor use only

Minimum clearance from walls or adjacent surfaces: 100 mm

Electrical Limits

Supply voltage fluctuation shall not exceed $\pm 10\%$ of the nominal voltage.

Operational Restrictions

The device shall not be operated under the following conditions:

- In residential or domestic environments
- In hazardous or explosive (ATEX-classified) environments
- With flammable, explosive or highly volatile substances
- For continuous unattended operation
- Without properly installed filters or with damaged components
- Using non-approved accessories or with unauthorized modifications

Material Compatibility

Liquids incompatible with device materials, including strong solvents, shall not be aspirated unless compatibility has been verified with the manufacturer.

Storage Conditions

The KENO PRO Vacuum Aspirator shall be stored in a clean, dry and dust-free indoor environment to prevent damage and ensure continued performance.

The following storage conditions shall be observed:

- Storage temperature: 5°C to 40°C
- Maximum relative humidity: 80% (non-condensing)

The instrument shall be stored on a stable surface and protected from direct sunlight, moisture, corrosive atmospheres and mechanical shock. Packaging or protective covers should be used during storage and transportation to prevent contamination or physical damage.

Intended Purpose

The KENO PRO Vacuum Aspirator is designed to generate controlled negative pressure for the aspiration, transfer and collection of liquid samples in laboratory environments. The device supports the safe handling of biological and chemical liquids by providing a closed aspiration system with appropriate filtration and containment.

Intended Users

This device is intended for use by trained laboratory personnel, including research scientists, laboratory technicians and diagnostic staff who are familiar with laboratory safety practices and the handling of potentially hazardous liquids.

Untended Environment

The KENO PRO Vacuum Aspirator is intended for indoor use in controlled laboratory environments, including but not limited to:

- Research laboratories
- Educational laboratories
- Diagnostic laboratories
- Industrial quality control laboratories

Uses Not Intended

The device is not intended for:

- Direct patient aspiration or clinical suction procedures
- Use with flammable, explosive or highly volatile substances
- Operation in hazardous or explosive (ATEX-classified) environments
- Continuous unattended operation

Overview

The KENO PRO Vacuum Aspirator is designed to generate controlled negative pressure for the aspiration, transfer and collection of liquid samples in laboratory environments. The device supports the safe handling of biological and chemical liquids by providing a closed aspiration system with appropriate filtration and containment.

KENO PRO - 4L (Premium)

1. Vacuum Aspirator
2. Collection Bottle (Polypropylene) - 4 L
3. Cap with Built-in CPC Valve Connectors
4. Self-Closing Couplings (PVDF)
5. Bottle Lifter for 4 litre bottle
6. Silicone Tubes
7. Power Adapter
8. Level Sensor Cable
9. Adapter Kit Box

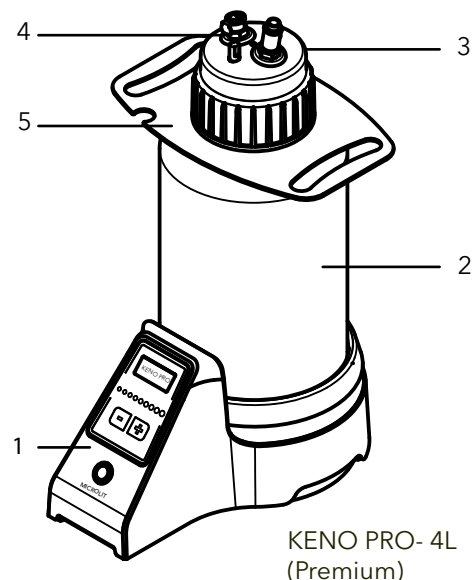
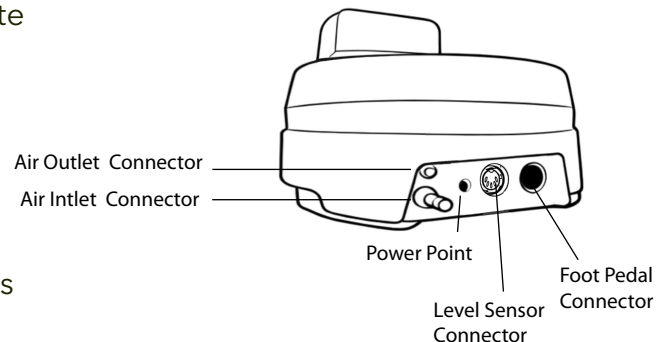
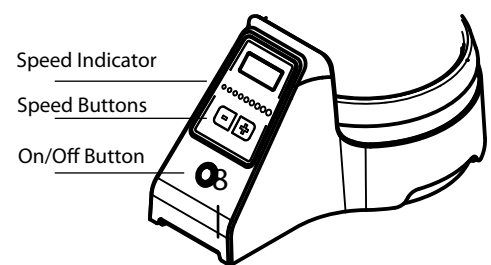
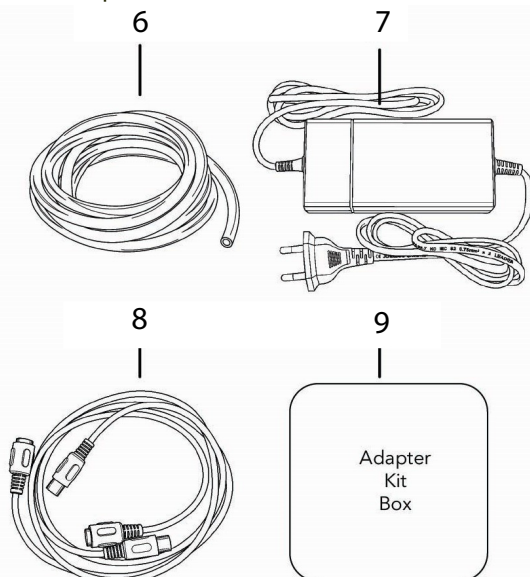

KENO PRO- 4L
(Premium)

KENO PRO - 4L (Economy)

1. Vacuum Aspirator
2. Collection Bottle (Polypropylene) - 4L
3. Cap with Built-in Connectors
4. Bottle Lifter for 4 litre bottle
5. Silicone Tubes
6. Power Adapter
7. Level Sensor Cable
8. Adapter Kit Box

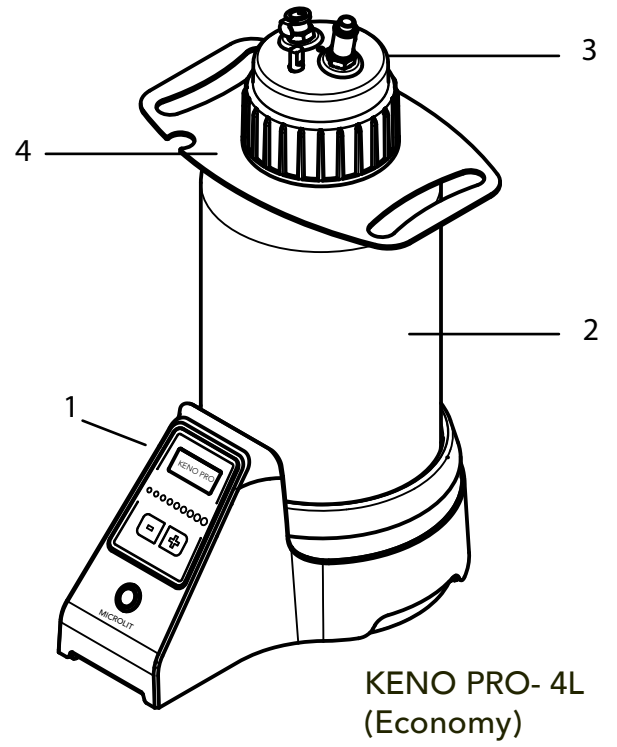
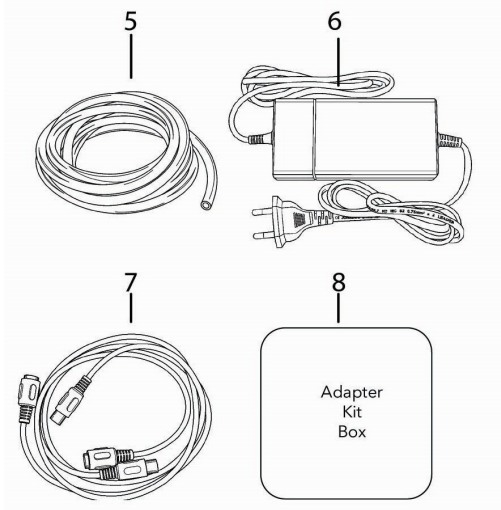

KENO PRO - 2L

1. Vacuum Aspirator
2. Collection Bottle (Polypropylene) - 2L
3. Cap with Built-in Connectors
4. Bottle Holder
5. Silicone Tubes (2 pcs)
6. Power Adapter
7. Level Sensor Cable
8. Adapter Kit Box

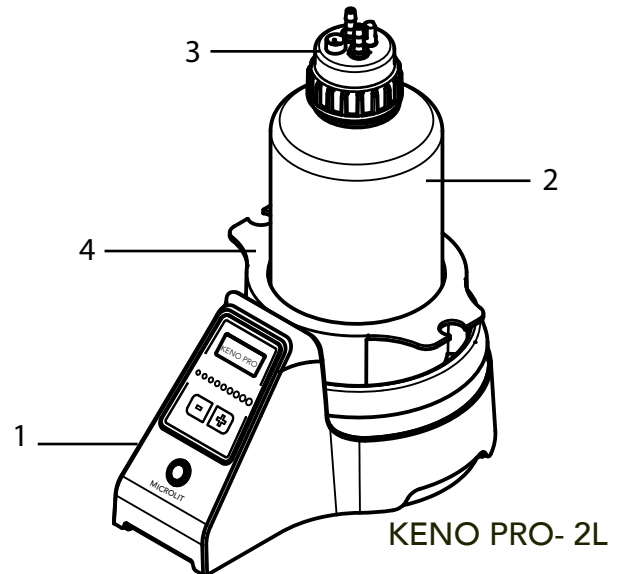
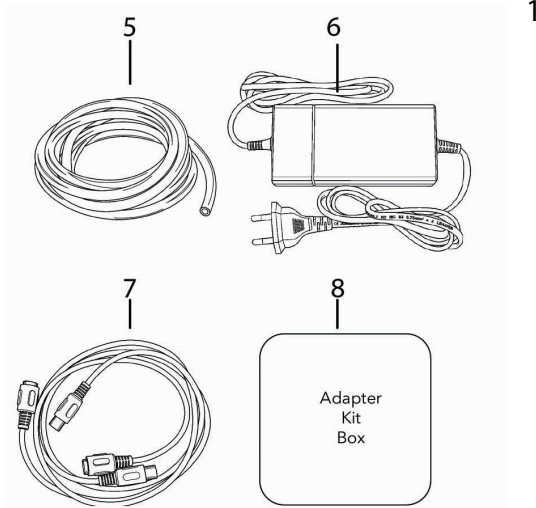

Adapter Kit Box

1. Needle - Single Channel, Ø2.5mm, 120mm, Stainless Steel
2. Needle - Single Channel, Ø1.5mm, 120 mm, Stainless Steel
3. Needle - Eight Channel, Ø1.5mm, Stainless Steel
4. Needle - Eight Channel for 200µL tip, with Ejector
5. Needle - 1 Channel for 200µL tip, with Ejector
6. Needle - 1 Channel for 1000µL tip, with Ejector
7. Hand Controller

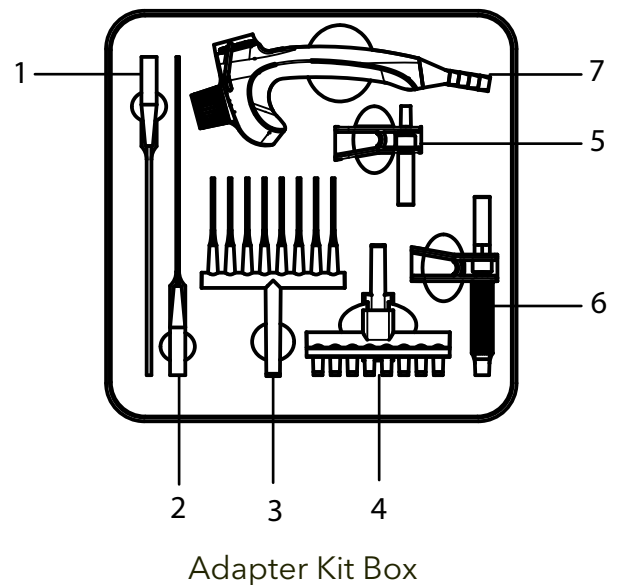

Accessories

1. Bottle Lifter
2. Trolley
3. Foot Pedal

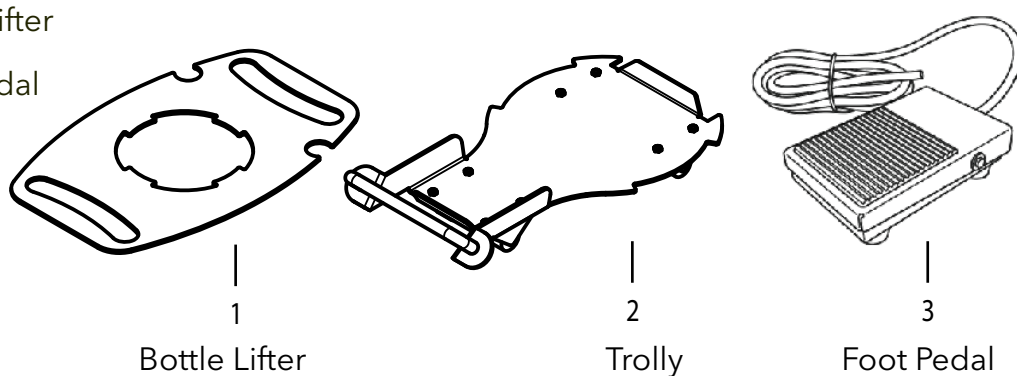

Installation Requirements

Location

Install the device on a clean, dry, stable laboratory bench away from heat sources, corrosive vapors and direct sunlight.

Environmental Conditions

Operate only within the specified ambient temperature and humidity range. Condensation must be avoided.

Installation & Setup

Unpacking & Inspection

Verify that all components supplied with the KENO PRO Vacuum Aspirator are included in the packaging and are free from visible damage. The exact contents may vary depending on the model and configuration ordered.

The packaging may include, but is not limited to, the following items:

- Vacuum Aspirator main unit
- Liquid collection bottle(s) with appropriate capacity
- Bottle cap or lid with integrated connectors
- Tubing, couplings and filtration components as applicable
- Bottle holder or lifter (model dependent)
- Level sensor cable
- Power adapter
- Adapter kits and accessories (as applicable)
- Instruction manual and related documentation

If any component is missing, damaged or does not correspond to the ordered configuration, do not connect the instrument to the power supply and report the issue to the supplier or manufacturer.

Power Supply

Insert the power adapter cable into the power point of the vacuum aspirator, and then connect it to a suitable grounded power socket.

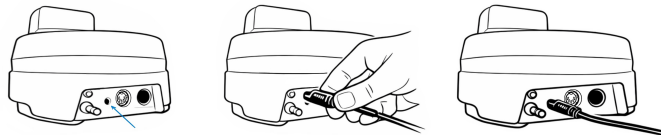

Bottle and Tube Connection

- Place the collection bottle into the instrument base.
- Secure the bottle lifter by screwing it firmly onto the bottle neck.
- Close the bottle with the cap and ensure it is tightened securely.
- The vacuum aspirator comes with two tubes:
Inlet tube (1 meter)
Outlet tube (0.5 meter)
- To connect the inlet tube, attach one end to the bottle cap and the other end to the hand controller.
- To connect the outlet tube, attach one end to the bottle cap and the other end to the air inlet connector of the aspirator.

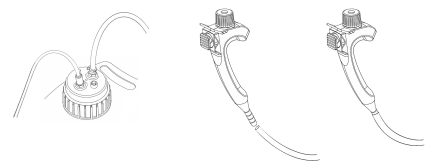
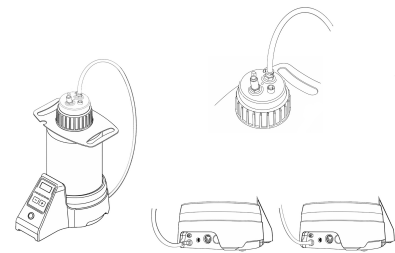
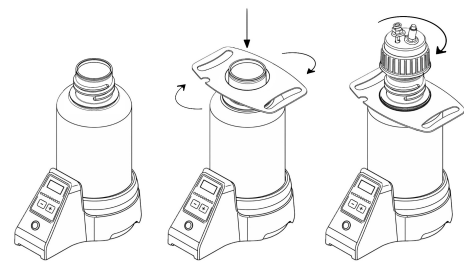

Level Sensor Connection

Connect the level sensor cable to the designated socket at the rear of the instrument. Connect the other end of the level sensor cable to the bottle cap. Ensure that the sensor pins and connectors are clean and dry before connection.

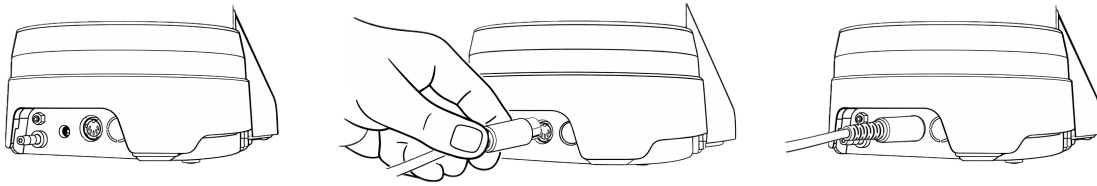

Steps to Attach an External Inline Filter

Please find below the step-by-step procedure for attaching an external inline filter:

- Turn off the system: Ensure the equipment is completely powered off before starting the process.
- Attach the filter: Remove the air outlet tube from the outlet connector and connect it to the filter. Now, insert the silicone tube which is attached on the other side of the filter firmly onto the outlet connector.
- Tighten the joints: Ensure all connections are properly tightened to prevent leaks.
- Inspect the setup: Ensure alignment and fittings before restarting the system.
- Turn on the system: Restore power and observe for any leaks or irregularities.

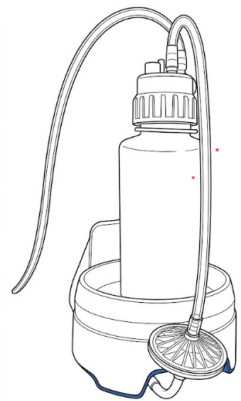

Operation

- Switch on the instrument by pressing the ON/OFF button. Once pressed, the button will illuminate.
- Allow a few seconds for the vacuum to build up in the collection bottle.
- Adjust the aspiration speed using speed button.
- Aspirate liquid by pressing the button on the hand controller fitted with a suitable tip.
- Monitor the liquid level in the collection bottle, especially when operating without a level sensor.
- Before opening the collection bottle, release the vacuum via the venting port on the cap or by aspirating air using the hand operator.
- Ensure that the bottle cap is tightly closed and the venting port is fully sealed during operation.

Use of Level Sensors

When the collection bottle is full, the level sensor automatically stops the vacuum pump.

If user wants the level sensor can be deactivated by disconnecting the sensor cable.

Cleaning, Disinfection and Sterilization

Proper cleaning, disinfection and sterilization are essential to ensure safe operation, prevent contamination, and maintain device performance. Always disconnect the instrument from the power supply before performing any cleaning, disinfection or maintenance activities.

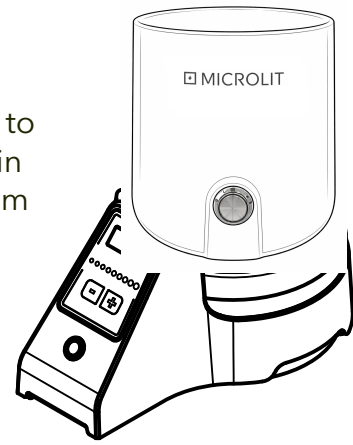

Cleaning

External Cleaning

- Clean the external housing using a soft, lint-free cloth dampened with a mild soap solution or mild laboratory detergent.
- 70% ethanol or isopropanol may be used for surface disinfection.
- Do not allow liquids to enter the pump housing or electrical components.
- Do not use bleach, abrasive cleaners or aggressive solvents.

Internal / Liquid-Contact Parts

- Disassemble the waste collection bottle, tubing, connectors and hand operator.
- Rinse thoroughly using water or compatible cleaning solutions approved for the materials of construction.
- After handling hazardous materials, flush the tubing and hand operator with water followed by 70% ethanol.

Disinfection

- Use laboratory-approved disinfectants compatible with the device materials.
- Follow the disinfectant manufacturer's instructions regarding concentration and contact time.
- Use chlorine-free and non-corrosive disinfectants only.
- Ensure all components are thoroughly rinsed and dried before reassembly.

Sterilization

Autoclaving

Only components explicitly identified as autoclavable may be autoclaved.

Autoclavable Components:

- Waste collection bottle
- Bottle lid
- Silicone tubing (30 Autoclavable Cycles)
- Hand operator

Autoclaving Conditions:

Polypropylene bottle: 121°C for ≥ 60 minutes

Glass bottle and hand operator: 121°C for ≥ 20 minutes

Important Notes:

- Keep the bottle lid loosely fitted during autoclaving.
- Disconnect PVDF tubing couplings before autoclaving.
- Inspect tubing after sterilization and replace immediately if signs of brittleness, discoloration, or damage are observed.

Non-Autoclavable Components:

- Pump unit
- Hydrophobic filters
- Electrical and electronic components

Chemical Sterilization

- Add a compatible disinfectant solution to the waste collection bottle.
- Allow adequate contact time as specified by the disinfectant manufacturer.
- Ensure the disinfectant is chlorine-free and non-corrosive.
- Rinse thoroughly after sterilization to remove residual chemicals.

Maintenance & Service

Preventive Maintenance

To ensure reliable operation, the following preventive maintenance schedule is recommended:

Daily

Perform a visual inspection for leaks, cracks, loose connections, or contamination.

Weekly

Clean waste collection bottles, tubing, hand operator, and external surfaces.

Monthly

Inspect hydrophobic filters, tubing elasticity, connectors, and seals. Replace worn or damaged components as necessary.

Consumables & Replacement Parts

The following components are consumables and may require periodic replacement:

Hydrophobic filters
Aspiration tubing
Collection bottles

Replace the hydrophobic filter at least once per year or immediately if liquid ingress occurs.

Use only KENO-approved consumables and replacement parts to ensure safety, performance, and regulatory compliance.

Service & Repairs

All servicing and repairs must be performed by authorized MICROLIT service personnel. Unauthorized servicing, modification, or repair of the instrument is strictly prohibited and may result in equipment damage, personal injury, or loss of warranty.

Technical Specification

KENO PRO	
Certifications	CE Certificate
IP Rating	IP41 Protection
Model No.	K-P4, K-E4, K-P2
Input Voltage	DC 24V, 1.2A
Vaccum Range	0 to -850 mbar (Adjustable)
Max flow rate in Air	15 L/min
Flow rate of liquid	23 mL/sec - 40 mL/sec
Noise at 1 meter distance	< 65 dB at maximum vacuum
Motor type	Brushless DC Motor
Collection bottle	2L/4L Polypropylene
Auto Shut Off	Yes
Weight	1.05 kg
Dimension	260 mm (depth) X 140 mm (height) x 90 mm (width)

Troubleshooting

Problem	Possible Causes	Solution
Device not running	No electrical power	<p>Plug the main adapter in the power source and in the device.</p> <p>Switch on the on/off button. LED will be illuminate.</p>
	Level sensor has been activated	Empty the bottle.
Aspiration is very low and/or the pump never stops running	Aspiration speed is set to minimum.	Press (+) & (-) button to control the Aspiration Speed
	Leak in the vacuum system	<p>Close the venting port by closing the sealing screw or sealing cap.</p> <p>Close the bottle lid tightly. Check tubing and filter for leaks.</p> <p>Reduce the residual flow of the hand controller by closing the screw opposite the operator button</p>
	Liquid overflowed thereby blocking filter	Empty the bottle and change the filter
	Tubing is blocked	Clean or change the tubing

Problem	Possible Causes	Solution
Level sensor activated erroneously (Bottle is not full)	Sensor cable is connected incorrectly	Fully insert the sensor cable with the correct orientation in the lid and base sockets.
Heating Issues	Leakage, causing the pump to run continuously.	There should be no heating. If heating occurs it may indicate a leakage. Please check the tubes and ensure the cap is properly fitted.
Inconsistent aspiration and unintended speed fluctuations	Twisting or pinching of Silicone Tube	Ensure inlet and outlet tubes are connected properly without any twisting or pinching.
Others	Foam activates the level sensor	Use an anti-foaming agent
	Soiled sensor pins	Clean pins inside the cap.
	Electromagnetic interferences disturb level sensor	Eliminate or inactivate the source of electromagnetic interference.

Warranty

The Vacuum Aspirator comes with a limited one-year warranty that commences from the date of purchase. Coverage is limited to repair or replacement at the manufacturer's discretion, provided the product is used solely in accordance with the provided instructions and under normal operating conditions.

Guidelines for Return

Follow these guidelines, before sending the instrument for repair:

- Please clean the instrument carefully.
- On no account should the sent instrument contain any reagent.
- The sent instrument can only be checked and repaired if it has been carefully cleaned and decontaminated, beforehand.
- Forcefully opening the instrument invalidates any warranty claim.
- While packing the instrument for return, please enclose a detailed description of the trouble that has occurred and the reagents that were used with the instrument

Disposal

The electrical and electronic equipment, including batteries, must be disposed of separately from household waste at the end of their service life.

In accordance with applicable Waste Electrical and Electronic Equipment (WEEE) regulations, electronic devices must be collected and disposed of through appropriate recycling channels, as per national and local regulations.

Batteries may contain substances that are harmful to the environment and human health. They must be disposed of separately in accordance with applicable battery disposal regulations.

Do not dispose of batteries in household waste, incinerate them or short-circuit them.

Subject to technical modifications without prior notice. Errors and omissions excepted.



Microlit India

629 Pakramau, Kursi Road, Lucknow 226026, India
Phone: +91 9918625629, Email: info@microlit.com
www.microlit.com

Microlit USA

33 Wood Avenue South, Suite 600, Iselin, NJ 08830, USA
Phone: +1 732 321 0852, Email: info-usa@microlit.com
www.microlit.us

Microlit LATAM

Business Place Ibirapuera, Alameda dos Jurupis, 1005,
Indianópolis, São Paulo, Brasil
Phone: +55 11 93269-5932,